



T2 EV Electric Terminal Tractor



The time is now to go electric

Kalmar Ottawa's third generation of electric terminal tractors will help improve the eco-efficiency of your operations while maintaining the highest levels of productivity and safety. With a range of modular battery options and charging solutions, we can work with you to design a solution that will deliver for your business.

A decade in the making

Our electrification journey began several years ago when we put our first prototypes into the field. Now with years of experience in operation, we have been able to identify where key changes needed to be made. These have all been brought together in our T2 EV electric terminal tractor, changes which have helped us design a terminal tractor that will exceed your expectations.

Eco efficiency built in

Your electric terminal tractor will produce zero carbon emission at source, making them cleaner and safer to operate. You can cut your carbon emissions even further by using green energy sources where available or start to generate and use your own power. Getting an electric terminal tractor is only the start of your eco-efficient journey. One that we will be with you every step of the way.

For complete peace of mind

All Kalmar Electric Terminal Tractors come with a 3 year/6500 hour warranty on major electric components, and a 6 year warranty on the batteries. Kalmar Ottawa also offers a full range of service packages and genuine parts to keep your terminal tractor operating optimally, thus minimizing downtime.

Three major changes

There are three distinct differences and many small ones to our new generation of electric terminal tractors for you to benefit from.

Charge times reduced. Our first big change has been to incorporate a DC FastCharge System, which has allowed us to decrease our charge time significantly.

Electric motor. The second is that we have eliminated the transmission from the driveline, moving to a direct drive solution where the electric motor is powering the drive axle, reducing the complexity of the driveline.

Ability to operate in extreme temperatures. Thirdly, we have included an Active Thermal Management System, which will allow your electric terminal tractor to operate optimally at full power in extreme temperatures. When all brought together you have the Kalmar Ottawa T2 EV Electric Terminal Tractor which can be charged quickly and easily, will operate optimally in extreme weather conditions, is easier to service & maintain.



With a range of modular battery options and charging solutions to deliver for your business.

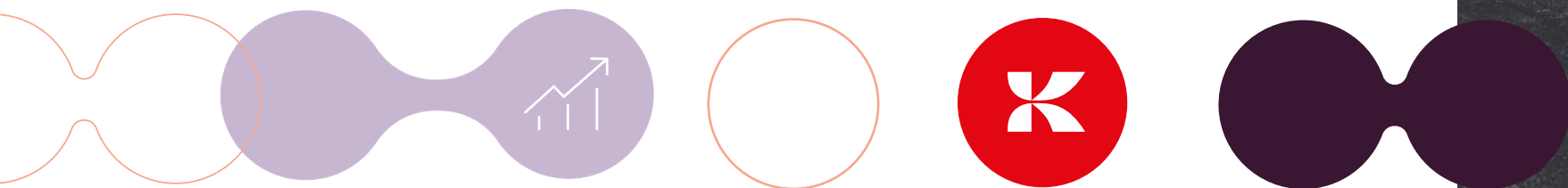

Our electric portfolio

Kalmar's electric terminal tractor is part of our complete range of eco-efficient solutions, which include electrically powered forklift trucks, reachstackers and empty container handlers.

Battery and Charging Monitoring

Real-time status on battery capacity and health along with charging usage and timing allows for optimised operational planning and usage.

MyKalmar INSIGHT

MyKalmar INSIGHT gives you the ability to monitor your fleet's operational status in real time no matter what type of your equipment you operate.



Additional Energy Storage

You can use additional energy storage units to capture excess power that you may have produced to use at a later time when required instead of buying from the grid.

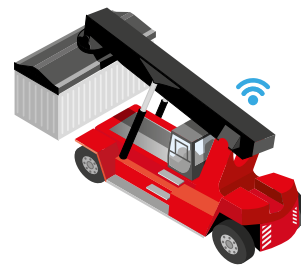

Terminal Tractors

The Kalmar Ottawa T2 EV electrically powered terminal tractor has been designed specifically for distribution centres and container terminals. There is a choice of different battery solutions designed to meet your operational requirements.

Power Cabinets

Power cabinets manage the required electricity flow from the grid to your charging points. Power cabinets are modular and the number required is dependent on the number of charging points required.

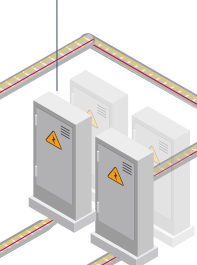

Local Grid

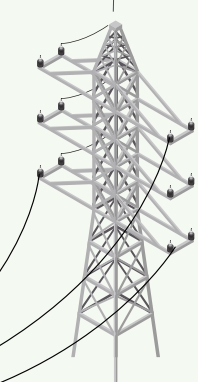

Site Power Grid



Sub Station Transformer

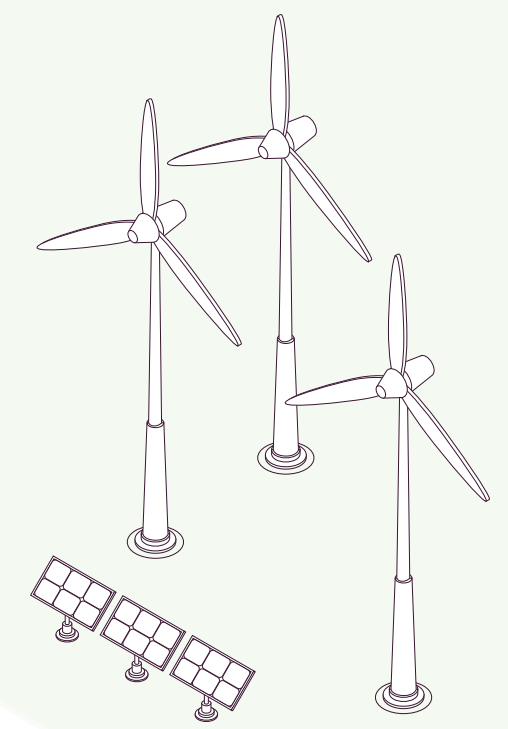

Charging Stations (EVSE)

We offer several different charging solutions. They can come with one or two CCS1 charging plugs.

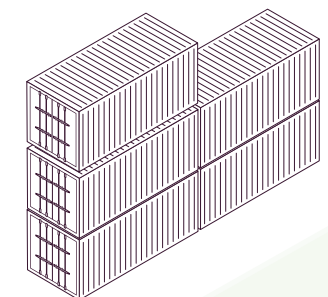
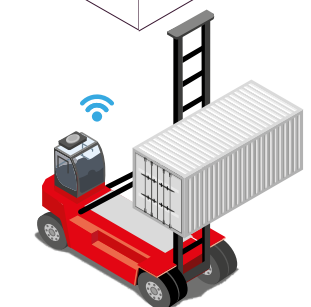
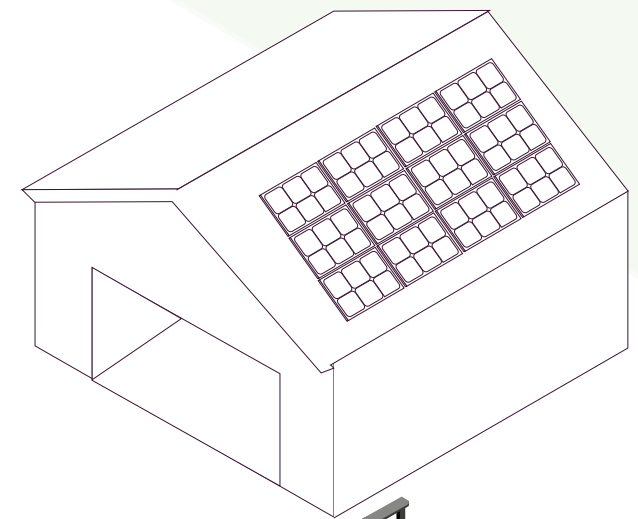
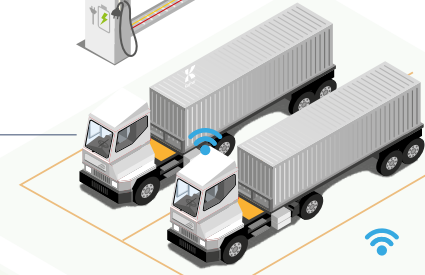

The power is in your hands

There are four different models available for you to choose from, two specifically designed for container ports and terminals, two for distribution applications including an on-road version available for North America.

Modular by design

Batteries and chargers are a big part of your overall investment making it critical that you get a solution that is matched to your operational requirements, which is why Kalmar has taken a modular approach to our battery and charging solutions. There are different charging solutions available with charging capacities up to 150kW and three different Li-ion battery capacities to choose from. Our battery solutions all come with a 6 year/2800 charge cycle warranty*. Kalmar can help you work out which battery option and charging solution is right for your business based on your current work cycles.

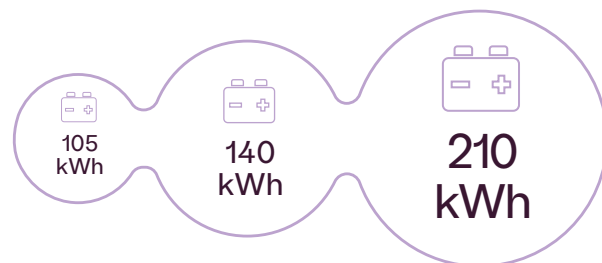

Managing your power

Kalmar's Battery Monitoring System continually monitors the voltage, temperature, coolant and current flow of your battery solution to ensure that it operates optimally over its lifetime. This system also controls the charging of the batteries by utilizing regenerative braking, sending recovered energy back into the battery packs making sure you are using the power available as efficiently as possible.

Productive in extreme weather conditions

Our portfolio of electrically powered terminal tractors all come fitted with a Thermal Management System, which allows your equipment to run optimally even in extreme weather temperatures. The system keeps your core battery temperature between 77-86°F for optimal performance even when the temperature outside gets down to -22°F or up to 122°F.

By linking the Thermal Management System to the Climate Control System energy used to heat or cool the operator's cabin will be reduced. Not only keeping your drivers comfortable, but reducing the overall energy required to run the AC or heating.



Safety in mind

With any electrically powered high voltage system you need to be extra safe which is why we have encased and shielded all high voltage lines. Should any connection be interrupted, the whole system will automatically shut down keeping your team safe. Knowing how to work with high voltage power sources is extremely important which is why Kalmar has specifically designed a High Voltage training course to enhance the skills of your workers and keep them extra safe.



* First life measured as 80% capacity left in the battery.

Designed for the driver

A cabin designed for your drivers

We have made sure that everything in our cabin has been ergonomically designed, down to the smallest detail. Your drivers will benefit from a comfortable driver's seat, a control panel that's always visible and within easy reach and even a brake pedal that has been redesigned to improve braking.

Excellent visibility

Our T2 EV has one of the widest front view windscreens you will experience. Side mirrors are fitted as standard to ensure your drivers can always see behind them. Plus, there's added visibility onto the rear platform and trailer through the standard rear window behind the driver.

Easy and safe access

Every Kalmar Ottawa T2 EV Electric Terminal Tractor has a standard rear door allowing direct access to the trailer hookups, and an optional side door entry.

More comfortable

We've made sure your driver will always be comfortable no matter what the conditions are like outside the cabin. With effective heating and cooling, an adjustable seat that can be mounted in three different positions and a handy cup holder - your driver will be more comfortable and productive. Being an electrically powered terminal tractor, your drivers will experience less vibrations and noise in the cabin, adding to their overall comfort.



The cabin display shown is currently being updated.

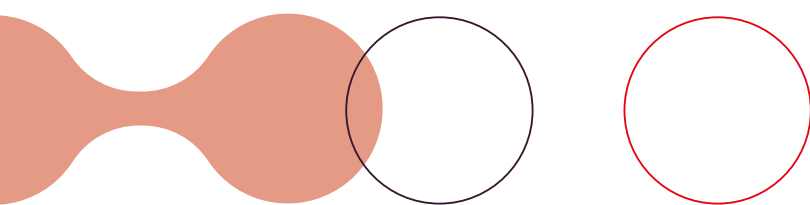

Options

Safety options

Kalmar Ottawa has a range of options that make operating your equipment even safer:

 Additional lighting. Extra lighting, particularly if you operate your machine at night, as you can bring greater operational visibility and safety for personnel working on the site. You can choose additional LED working lamps on specific positions.

Other safety features you might want to consider:

- Fifth Wheel secondary locking device and sensors for extra security.
- Trailer stops to protect your cabin.
- Reflective stripping for extra visibility in limited or no light.

Productivity options

There are a range of options* from Kalmar Ottawa that can help raise your productivity:



DOT Approved. Our terminal tractors have been certified to operate on the road in certain markets with a restricted speed limit.



A range of lifting capacities to choose from:

- 81,000 lbs. to 195,000 lbs.



Various wheelbases:

- 126 inch to 136 inch.

To help make your trailer picking more productive there are available:

- Beavertail and skid ramps
- Quick Trailer Air Delivery System.





Making sure your business never stops

With over 170 dealer locations across the country, you will always get the support you need.

Your local dealer can discuss a range of financing and service options with you, tailored to meet your exact business needs. Plus, with a state-of-the-art parts distribution system, you will have immediate access to over \$10million worth of spare parts stocked on our dealers' shelves.

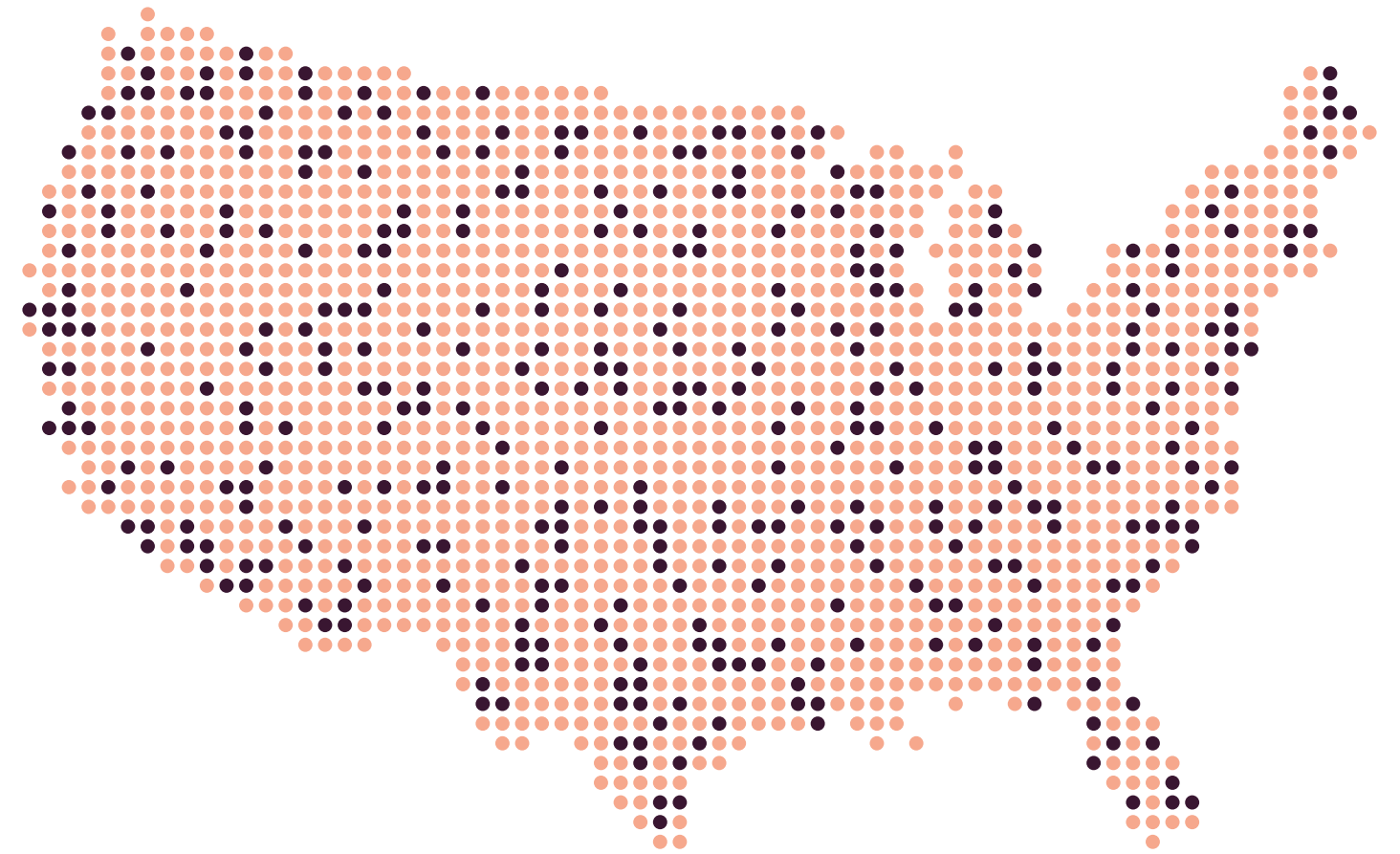

Over 170 dealers around the country to ensure you'll always get the support you need.

MyKalmar INSIGHT

Turning data into actionable, impactful insights

MyKalmar INSIGHT* is a performance management tool for cargo handling, which gives you an easy to use overview of your fleet operations, by aggregating data from multiple sources, including equipment built by other manufacturers. This information is then accessed through an easy to use interface that is available on mobile, tablet or more traditional screens.

You can review your entire fleet activities, schedule maintenance and order the required parts automatically. All enabling you to take action on real-time information, that will help improve your overall operations immediately. MyKalmar INSIGHT can be fitted as an option for all new Kalmar equipment, and can be retrofitted into existing Kalmar equipment or those built by other manufacturers.

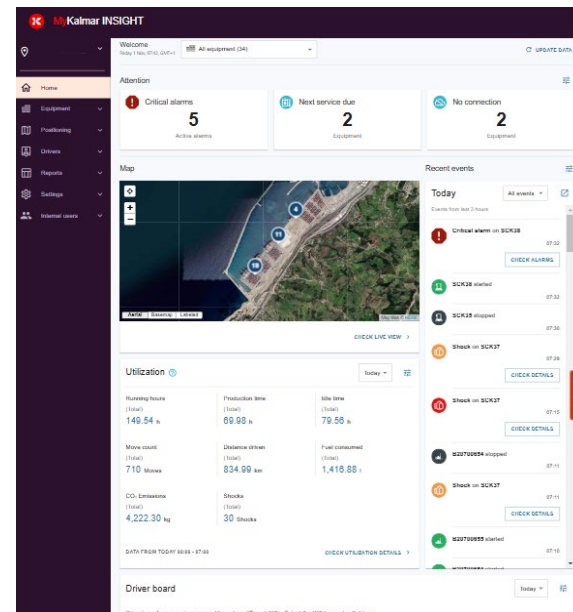

*Installation costs and/or an annual subscription fee may apply.

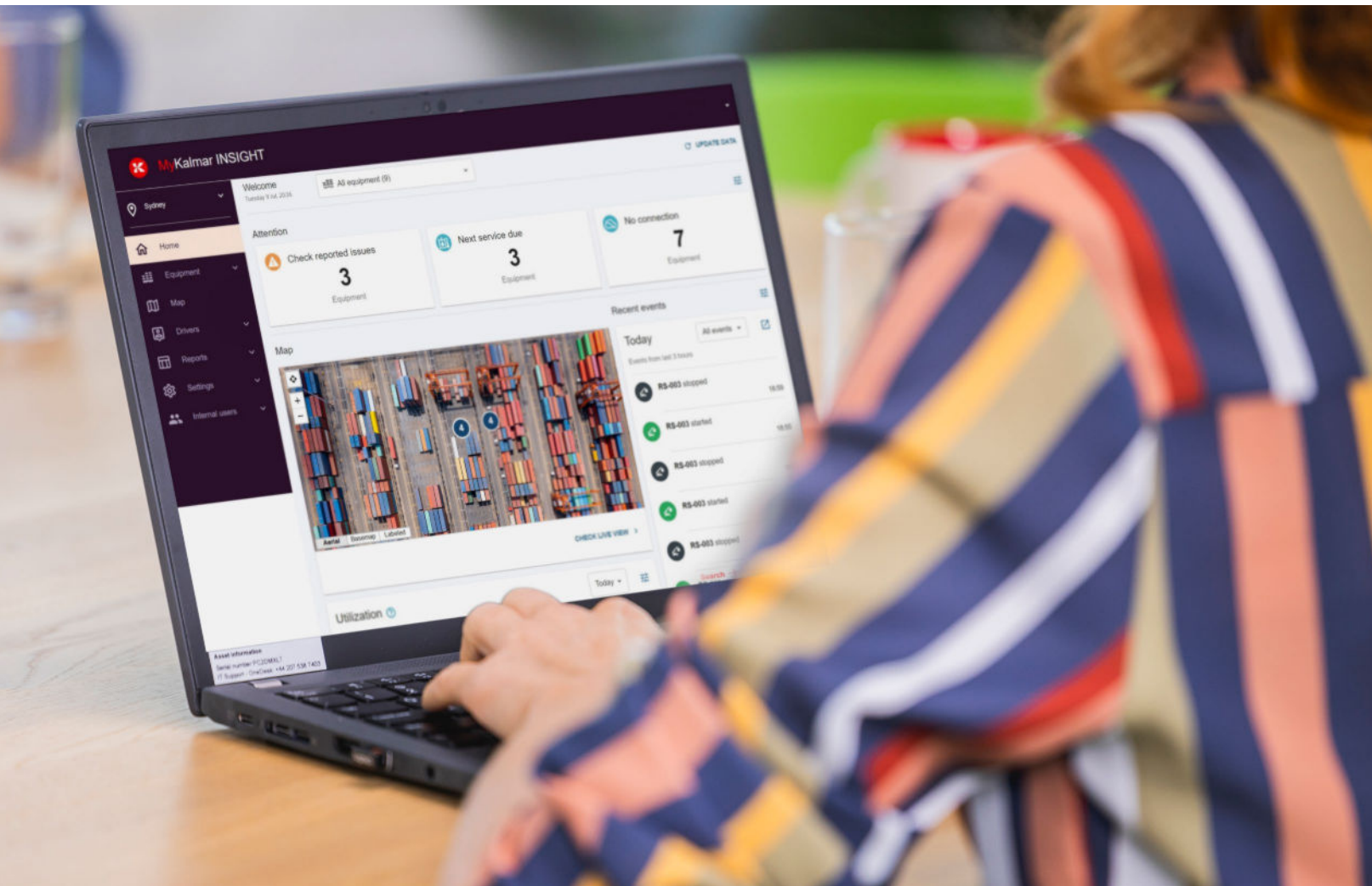

Kalmar training

Enhance your skills

To get the most out of your new machine our training centre offers a range of courses for both your technicians and operators. Operators can be taught how to drive the machine for optimum performance and minimum waste, and to learn what needs to be checked daily for optimal safety. Technicians can be educated with the knowledge they need to keep your new equipment in top condition in a safe way. Courses are a mix of theory and hands-on experience.



Standard

Kalmar Ottawa T2 EV

Chassis

- 14"x4.25"x3.5" steel 50,000 PSI 3/8" formed c-channel
- 0.25" steel 30,000 PSI formed "L" reinforcer
- Welded rear axle bracket & mid frame cross member
- Reinforced removable bumper with 55° taper curb side
- Integral front and rear tow points
- 126" wheelbase

Steer Axle (Front)

- See model specification
- "S" cam type 16.5"x 5" brakes
- Automatic slack adjusters

Drive Axle (Rear)

- See model specification
- "S" cam type 16.5"x 7" brakes
- Automatic slack adjusters

Wheels (Tires & Rims)

- See model specification to the right
- Hub piloted

Suspension

- Front—parabolic 3-leaf spring, lube free, shackle free
- Solid mount rear axle

Steering System

- Power assisted integral gear type with mechanical back-up

Powertrain

- Electric traction motor 302 HP cont. / 609 HP peak, 1547 lb*ft cont. / 2520 lb*ft peak
- Regenerative braking
- Power battery 600V nominal
- Charging standards CCS1
- Battery thermal management system (-22°F to +122°F)

Hydraulics

- 2300 PSI max. operating pressure
 - 20 gal. hydraulic tank with 10 micron internal return filter
 - 30 gpm system
- Steering system
 - 2350 PSI max. operating pressure

Lifting Boom

- See model specification
- Holland FW-35TT fifth wheel with 80,000 lb. plate rating
- Double acting cylinders with upper and lower spherical bearings
- 17" lift height

Pneumatic System

- 12.6-18.9 CFM air compressor
- 5334 cubic inch reservoir capacity
- Color-coded air lines, complies to TMC Recommended Practices
- Air brakes

Electrical System

- 24V low voltage system with 12V available
- Two (2) 12V 750 CCA batteries
- Battery disconnect switch
- LED cab interior lights
- LED head lights
- LED rear lights (Stop/Turn/Tail)
- LED rear facing high mount flood light on curb side of cab
- Electric back-up alarm
- All wires color and number coded
- Two (2) 24V, 270A HV/LV converters

Cabin

- Steel and composite cab with aluminium sliding rear door
- ROPS compliant (roll-over protection structure)
- High roof cab
- 3-point cab mounting with air suspension
- Laminated solar grey window in rear door
- Air ride seat with isolator and 2-point retractable seat belt
- Mounting plate for yard management system
- Coat hook behind driver seat
- Cup holder
- Cab insulation for thermal protection and noise abatement
- Cab tilt:
 - 40° with 90° tilt capability
 - Electric over hydraulic cab tilt system
- West coast 16"x7" mirrors

Operator controls

- Suspended pneumatic brake pedal and electronic throttle pedal
- Joystick controlled lift system
- Keyed 4-position ignition switch

- Push button drive and reverse (DNR) control
- 16" steering wheel

Climate

- Integral heating/ventilation system with (3) vents for driver: (4) front and (2) side defrost vents
- Air conditioning
- 15kW cab heating system
- High air flow heater/defroster with molded air ducts
- Electric pantograph windshield wiper

Information Systems

- Digitally display w/touchscreen

Various warning lights & signals

- Battery State of Charge (SoC)
- Hour Meter
- Odometer
- Speedometer
- Critical Situation Indicators

Fleet Management

- Equipped with telemetric hardware for MyKalmar INSIGHT

Color

- Cabin:
 - Metal structure/components - Full immersion, multi-stage, "E" coat with white powder top coat
 - Composite components - Color impregnated
 - Under cab - Rubberized undercoating
- Chassis: Black powder coat
- Rims: White powder coat
- Grab handles, steps and platforms: Yellow powder coat

Warranty

- Kalmar base warranty 24 months / 6000 hours
- Frame Warranty
- Electrical Component Warranty
 - 3 year / 6500 hours
- Kalmar Battery Warranty

Model specifications

Kalmar Ottawa T2 EV D81-50 DOT*

Distribution application
81,000 lbs. GCW
50,000 lbs. lift capacity

Axles

- Front: Kalmar FA11, 20,000 lb. Rated
- Rear: Kalmar RA37 83,000 lb. @ 12.5 MPH

Wheels (Tires & Rims)

- 11R22.5, 8.25 x 22.5 - 335mm BC

Energy Storage

- 105kWh, 140kWh or 210kWh

Lifting Boom

- Distribution Lift Boom
- 5" Lift Cylinders

Kalmar Ottawa T2 EV CT150-60

Container Terminal application
150,000 lbs. GCW
60,000 lbs. lift capacity

Axles

- Front: Meritor MFS20 20,000 lb. Rating
- Rear: Meritor MOR32 70,000 lb. Rated

Wheels (Tires & Rims)

- 280/75R22.5 8.25 x 22.5 - 335mm BC

Energy Storage

- 140 kWh or 210kWh

Lifting Boom

- Heavy Duty Lift Boom
- 5" Lift Cylinders

Kalmar Ottawa T2 EV D110-50

Distribution application
110,000 lbs. GCW
50,000 lbs. lift capacity

Axles

- Front: Kalmar FA11, 24,000 lb. Rated
- Rear: Kalmar RA37, 83,000 lb. @ 12.5 MPH

Wheels (Tires & Rims)

- 11R22.5, 8.25 x 22.5 - 335mm BC

Energy Storage

- 105kWh, 140kWh or 210kWh

Lifting Boom

- Distribution Lift Boom
- 5" Lift Cylinders

Kalmar Ottawa T2 EV CT195-70

Container Terminal application
195,000 lbs. GCW
70,000 lbs. lift capacity

Axles

- Front: Meritor MFS20, 20,000 lb. Rating
- Rear: Meritor MOR32, 70,000 lb. Rated

Wheels (Tires & Rims)

- 310/80R22.5, 9.00 x 22.5 - 335mm BC

Energy Storage

- 140 kWh or 210kWh

Lifting Boom

- Heavy Duty Lift Boom
- 6" Lift Cylinders

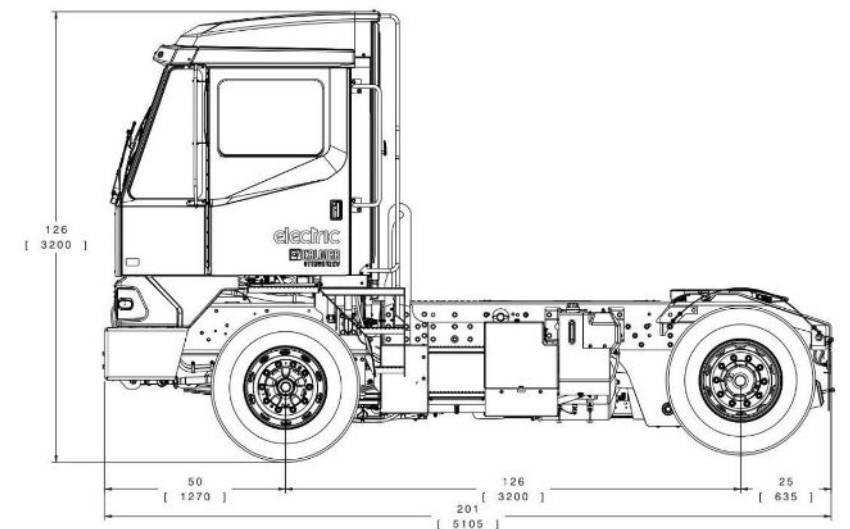
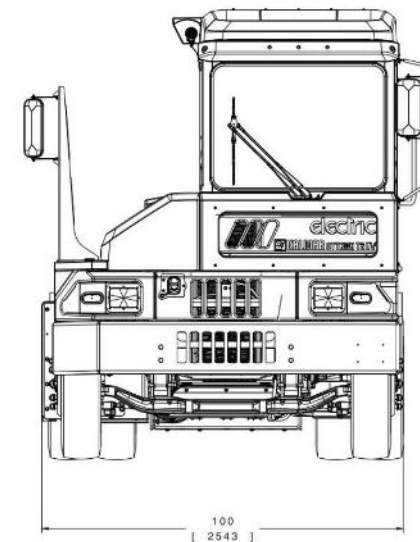

* North American on-highway

Specifications

		T2 EV		T2 EV		
		D81-50 DOT	D110-50	CT150-60	CT195-70	
Driving data	Travelling speed forward, - unloaded - MPH	33	25	22	22	
	Travelling speed forward, - at rated load - MPH	15	15	15	10	
	Gradeability, loaded – at rated load (%)	3	3	3	3	
Weight of truck	Vehicle weight - unladen ** - lbs	17,600	17,600	19,200	19,200	
	Maximum Gross Combination Weight Rating - lbs	81,000	110,000	150,000	195,000	
	** Weights are calculated values and may vary based on configuration					
Driveline	Drive motor/traction motor, rated power (continuous) - HP	302	302	302	302	
	Drive motor/traction motor, rated power (peak) - HP	609	609	609	609	
	Drive motor/traction motor, rated torque (continuous) - lb*ft	1547	1547	1547	1547	
	Drive motor/traction motor, rated torque (peak) - lb*ft	2520	2520	2520	2520	
	Energy consumption (kWh/h)	8-10	8-10	15-18	15-18	
Front Axle (Steer)	Manufacturer / Model	Kalmar FA11	Kalmar FA11	Meritor MFS-20	Meritor MFS-20	
	Dynamic capacity - lbs	12,000	24,000	20,000	20,000	
Rear Axle (Driving)	Manufacturer / Model	Meritor RS24-160	Kalmar RA37	Meritor MOR-32	Meritor MOR-32	
	Ratio	12.2:1	12.2:1	16.92:1	16.92:1	
	Dynamic capacity - lbs	30,000 (13,608) @ 15 MPH	83,800 (38,000) @ 12.5 MPH	70,500	70,500	
Wheels	Manufacturer / type designation	Generic On-Highway	Generic On-Highway	Continental TerminalMaster	Continental TerminalMaster	
	Tire dimensions, front – rear (inch)	11R22.5	11R22.5	280/75R22.5	310/80R22.5	
	Overall Diameter - inch	41.4	41.4	39.2	42.7	
	Rim dimensions, front – rear (inch)	8.25 x 22.5	8.25 x 22.5	8.25 x 22.5	9.00 x 22.5	
	Bolt circle - inch	13.19	13.19	13.19	13.19	
	Number of wheels, front / rear (driven)					
	Max. Pressure - PSI	105	105	145	145	
5th Wheel	Manufacturer / type designation	Holland / FW35-TT	Holland / FW35-TT	Holland / FW35-TT	Holland / FW35-TT	
	Vertical capacity - lbs	80,000	80,000	80,000	80,000	
	King-pin diameter inch	2	2	2	2	
Lifting cylinders	Type	Single stage - double acting	Single stage - double acting	Single stage - double acting	Single stage - double acting	
	Lifting capacity - lbs	50,000	50,000	60,000	70,000	
	Lifting height - inch	17	17	17	17	
	Lifting speed (s) *	7	7	7	7	
	Lowering speed (s) *	5	5	5	5	
	* Theoretical calculated values					
Cabin	Cabin position	Left hand drive	Left hand drive	Left hand drive	Left hand drive	
	Cabin upholstery	Basic	Basic	Basic	Basic	
	Driver seat type	Air suspended	Air suspended	Air suspended	Air suspended	
	Display type	Digital display (mph, ° Fahrenheit, PSI)	Digital display (mph, ° Fahrenheit, PSI)	Digital display (mph, ° Fahrenheit, PSI)	Digital display (mph, ° Fahrenheit, PSI)	
Battery	System voltage (nominal) (V)	600	600	600	600	
	Charging inlet capacity (kW), max	150	150	150	150	
	Charging inlet standard	CCS1	CCS1	CCS1	CCS1	
Dimensions	L3 - Wheelbase - Inch	126	126	126	126	
	L - Overall Length - Inch	201	201	201	201	
	L2 - Distance between centre of front axle and front bumper - Inch	50	50	50	50	
	L5 - Distance between centre of rear axle and rear crossmember - Inch	25	25	25	25	
	B - Width - Inch	100	100	100	100	
	H8 - 5th wheel down height - Inch	46	46	46	46	
	H6 - Cabin height - Inch	126	126	126	126	
	G - Ground clearance (at center of truck)- Inch	11	11	11	11	
	C1 / C2 - Trailer clearance, boom up / boom down - Inch	89 / 93	89 / 93	89 / 93	89 / 93	



Kalmar
Ottawa

Kalmar USA Inc.
415 East Dundee St.
Ottawa, KS 66067, USA
Telephone: +1-785-242-2200

www.kalmarottawa.com

Published by Kalmar, Copyright © Kalmar Corporation 2025.
All rights reserved.

